

RF AMPLIFIER

MODEL QBH-8872

Available as: QBH-8872, 0.500" Sq. Package (E52-19422)

Features

- High Gain: 10.0 dB Typical
- High Power: +27.5 dBm Typical
- Operating Temp. - 40 °C to +70 °C
- Environmental Screening Available

Specifications

CHARACTERISTIC	TYPICAL Ta= 25 °C	MIN/MAX Ta = -40 °C to +70 °C
Frequency	30 - 2000 MHz	30 - 2000 MHz
Gain (dB)	10.0 ± 1.0	—
Gain vs. Temperature	—	+1.0/-1.0 Max.
Gain Flatness	1.0	1.2 Max.
Reverse Isolation (dB)	-18	-17 Min.
VSWR In	1.9:1	2.0:1 Max.
VSWR Out	1.9:1	2.0:1 Max.
1 dB Compression (dBm)	+27.5	+27 Min.
Output Intercept point 3rd Order	+41	+40 Min.
2nd Order	+47	+46 Min.
Noise Figure (dB)	5.2	6.0 Max.
Power Vdc	+15	+15
mA	410	450 Max.

Maximum (No Damage) Ratings

Ambient Operating Temperature -55 °C to +125 °C
 Storage Temperature -65 °C to + 150 °C
 Case Temperature + 125 °C
 DC Voltage + 17 Volts
 Continuous RF Input Power + 13 dBm
 Short Term RF Input Power 50 Milliwatts (1 Minute Max.)
 Maximum Peak Power 0.5 Watt (3 µsec Max.)

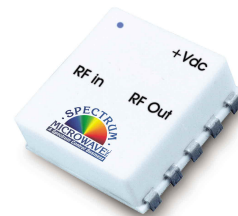

Notes:

1. Specifications are guaranteed when tested in a 50 Ohm system. Specifications indicated as typical are not guaranteed.
2. Noise Figures increase below 500 MHz

Revision 10/1/2013

Typical Performance Data

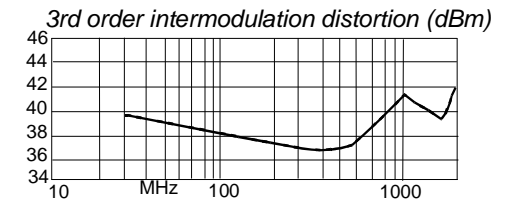
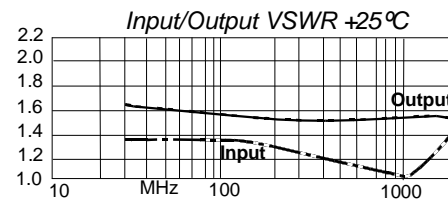
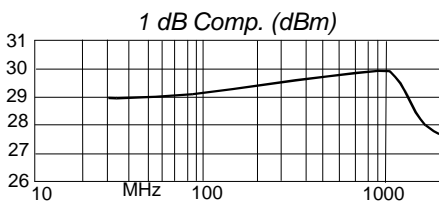
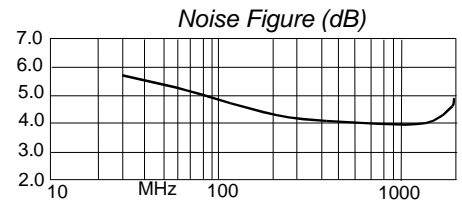
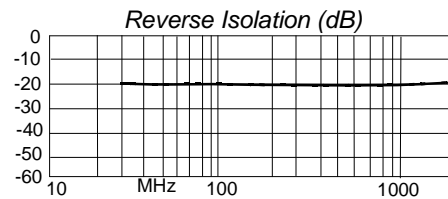
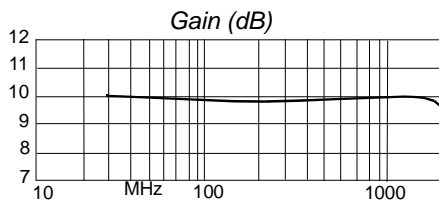

Legend ——— + 25 °C

Linear S-Parameters Data

FREQ. MHz	-- S11-- dB Ang	-- S21-- dB Ang	-- S12-- dB Ang	-- S22-- dB Ang
30	-16.7 -28.7	10.1 -175.6	-19.3 5.5	-12.0 163.0
600	-22.6 -76.9	9.8 92.6	-19.2 -59.5	-13.6 104.4
800	-27.2 -114.9	9.8 63.1	-19.4 -78.8	-13.8 82.8
1000	-32.4 151.2	9.9 33.5	-19.5 -98.0	-13.7 65.4
1200	-25.7 88.5	9.9 3.2	-19.7 -117.4	-14.0 51.3
1400	-21.1 57.9	9.9 -27.7	-19.8 -136.7	-13.7 41.6
1600	-19.1 38.4	9.8 -58.0	-20.1 -154.4	-13.8 29.6
1800	-16.6 14.7	9.6 -89.5	-20.1 -172.6	-12.2 24.1
2000	-16.2 2.9	9.5 -120.0	-20.1 169.2	-10.6 9.4



Spectrum Microwave · 2144 Franklin Drive N.E. · Palm Bay, Florida 32905 · PH (888) 553-7531 · Fax (888) 553-7532

www.SpectrumMicrowave.com Spectrum Microwave · 2707 Black Lake Place · Philadelphia, Pa. 19154 · PH (215) 464-4000 · Fax (215) 464-4001

NOTES: UNLESS OTHERWISE SPECIFIED,

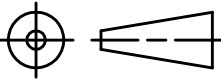
1. INTERPRET DWG PER ASME Y14.100.
2. INTERPRET THIRD ANGLE PROJECTION  (ISO-A).
3. DIMENSIONS ARE IN INCHES [MM].
4. INTERPRET DIMENSIONING SYMBOLS PER ASME Y14.5M.
5. DO NOT SCALE THIS DRAWING.
6. ALL PRINTED PATTERN TOLERANCES: $\pm .001$.
7. ALL DRILLED FEATURES: $\pm .002$.

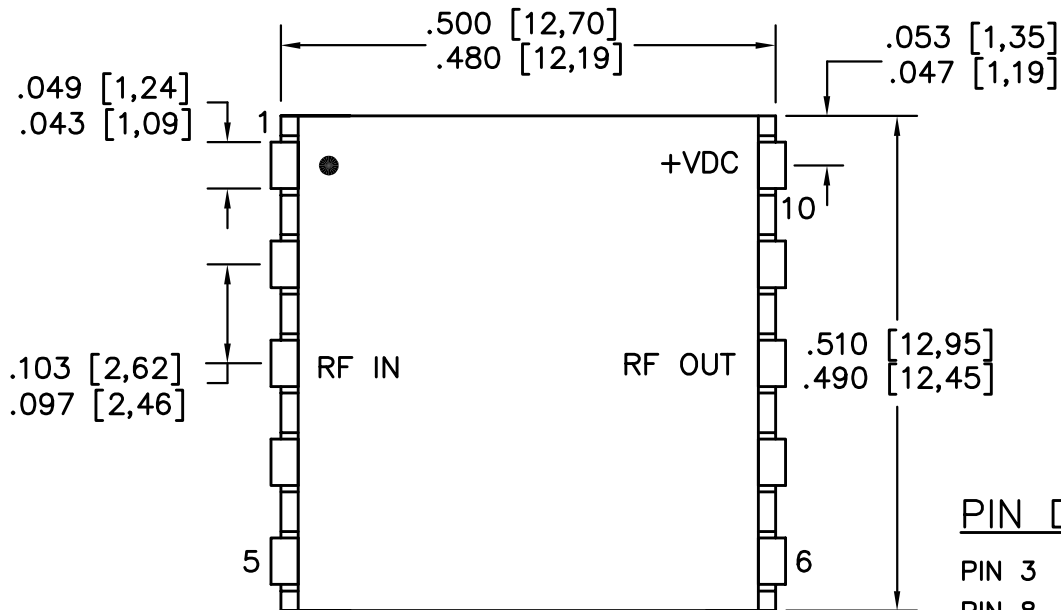

PIN DESIGNATIONS:

- PIN 3 RF INPUT
- PIN 8 RF OUTPUT
- PIN 10 DC VOLTAGE
- ALL OTHERS GROUND

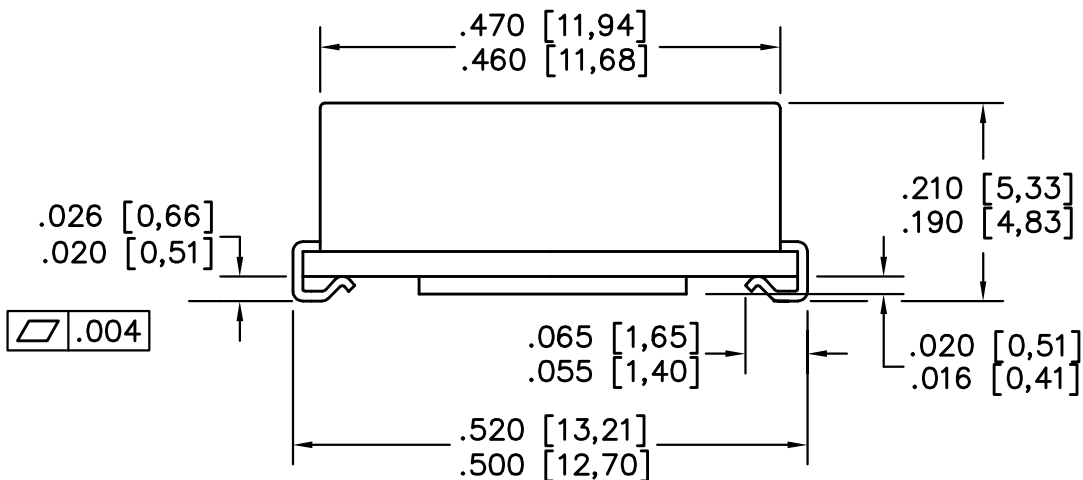

SPECTRUM MICROWAVE, INC	SIZE	CAGE CODE	DWG NO.
	A	55027	080-10117-0001
TITLE	SCALE:	REV	SHEET
OUTLINE DRAWING	5/1	F.2	2 OF 3

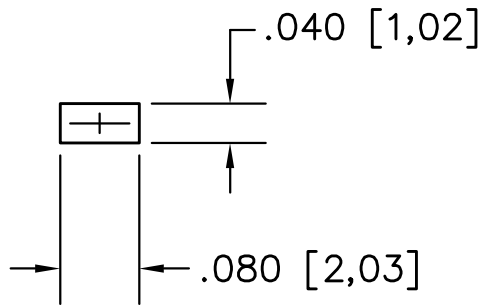

VIEW A
10 PLACES

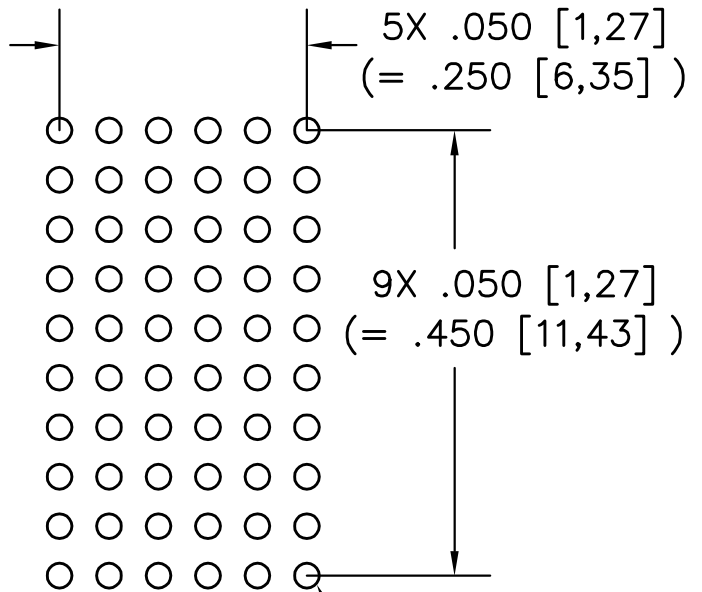

VIEW B

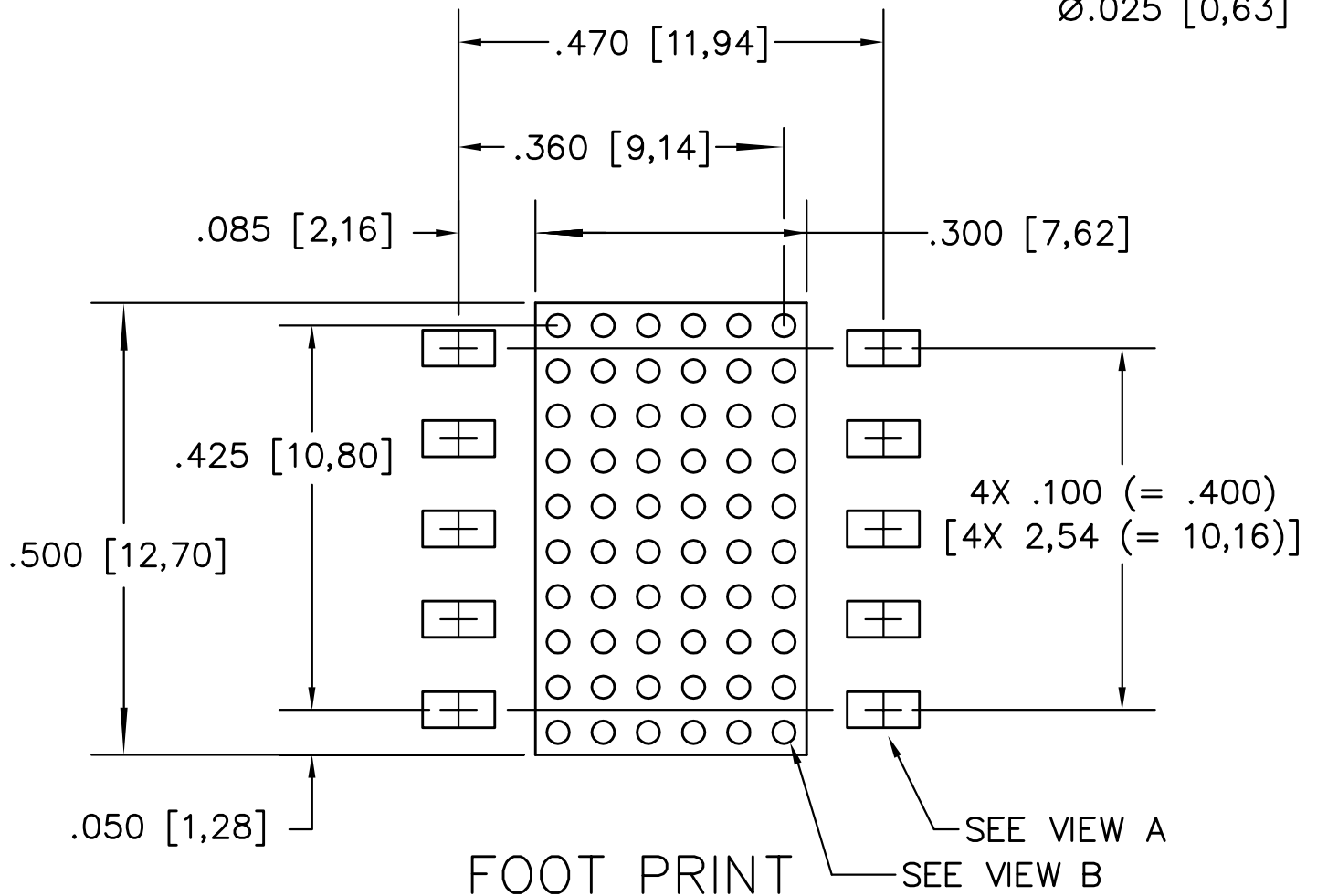

FOOT PRINT

SPECTRUM MICROWAVE, INC TITLE OUTLINE DRAWING	SIZE A	CAGE CODE 55027	DWG NO. 080-10117-0001		
	SCALE: 5/1	REV F.2	SHEET 3	OF 3	