

NOTES:

- 1. HOUSING & SEAL COVER ALUMINUM, COVER IS LASER WELDED TO FORM A HERMITIC SEAL.
HOUSING: IS NICKEL PLATED PER AMS-C-26074 CLASS 3, GRADE B,
WELD COVER: CHEMICAL FILM MIL-DTL-5541, TYPE II CLASS 3

REVISIONS				
ECN	REV.	DESCRIPTION	CHNG/DATE	APPVD/DATE
XXXXX	-	RELEASE	2016-08-30	

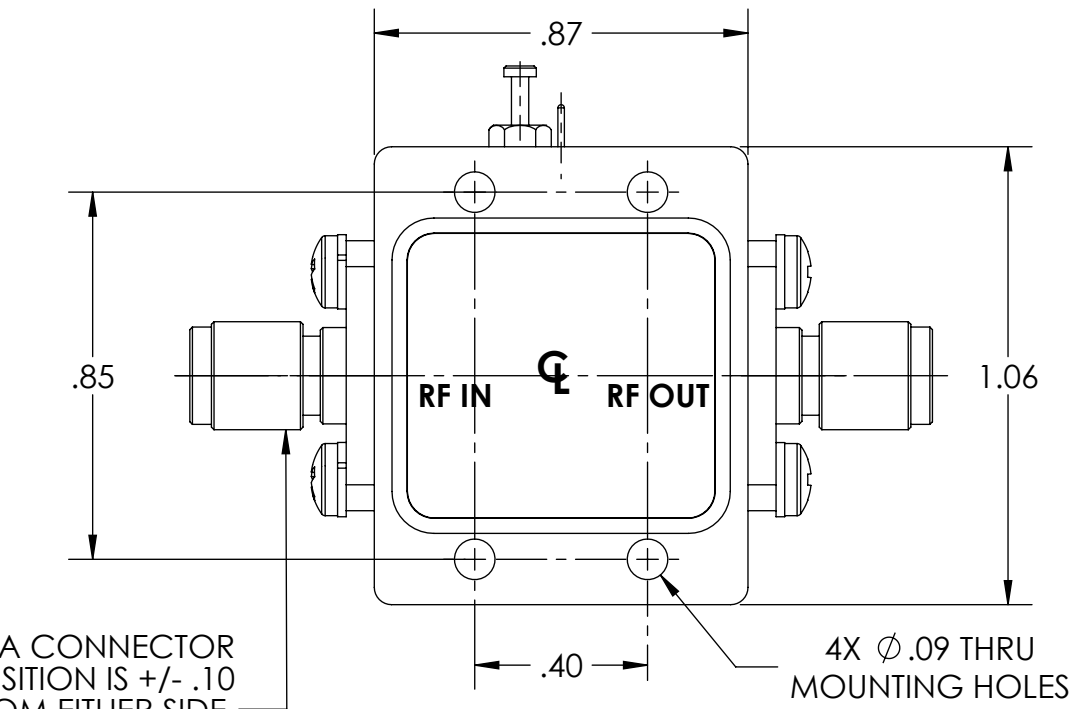
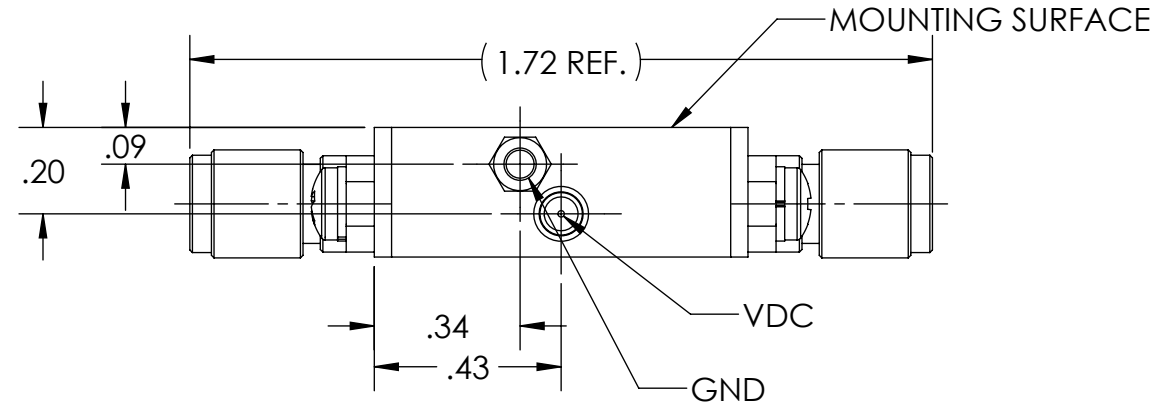
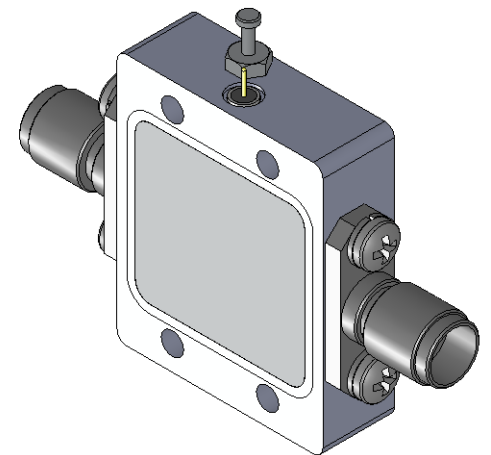

SMA CONNECTOR POSITION IS +/- .10 FROM EITHER SIDE OF THE CENTER LINE TYP BOTH SIDES

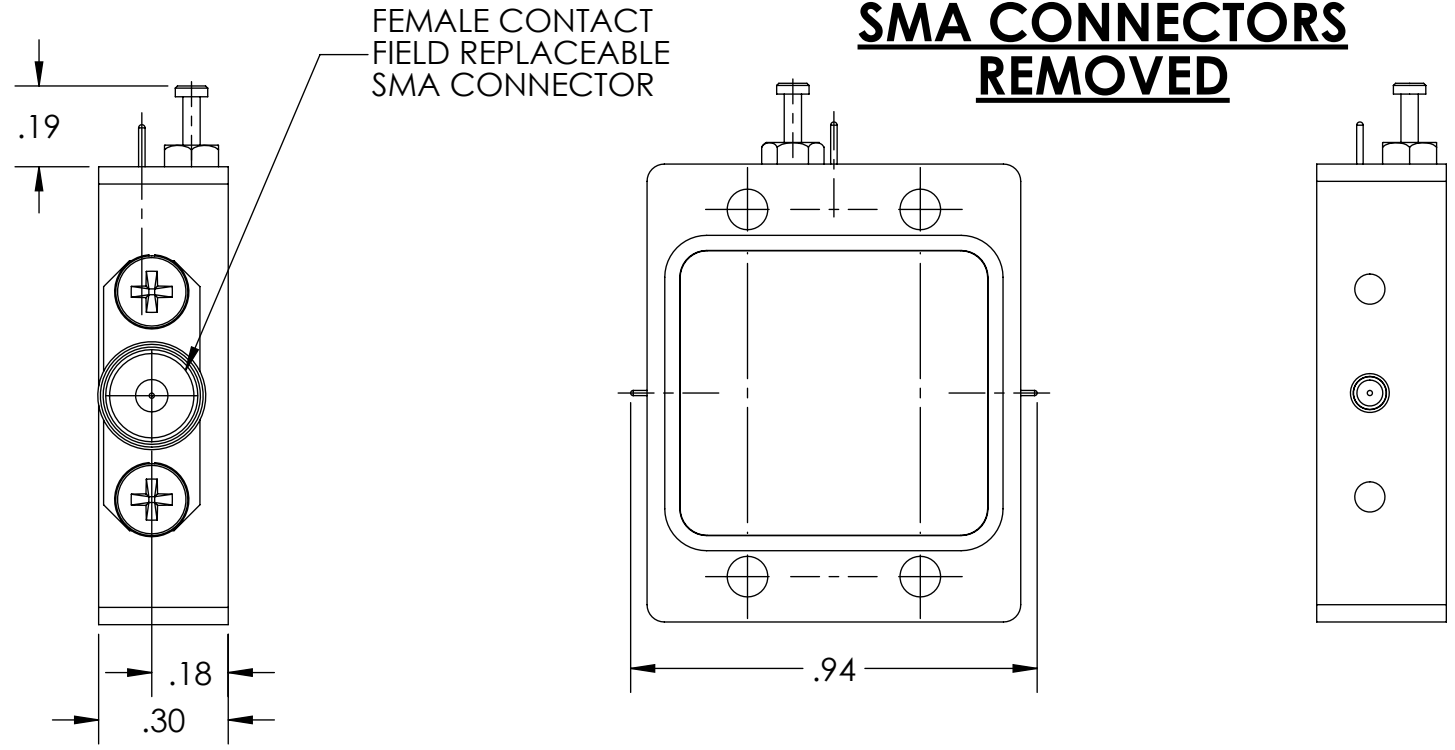

SEE SEPARATE PARTS LIST IN ELECTRONIC STORAGE

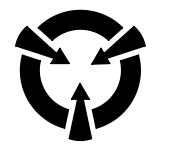

CAUTION

THIS ASSEMBLY CONTAINS PARTS SENSITIVE TO DAMAGE BY ELECTROSTATIC DISCHARGE (ESD). USE ESD PRECAUTIONARY PROCEDURES WHEN TOUCHING, REMOVING OR INSERTING

SPECTRUM MICROWAVE PROPRIETARY INFORMATION
THIS DOCUMENT IS THE SOLE PROPERTY OF SPECTRUM MICROWAVE, INC. THE RELEASE OF DATA CONTAINED IN THIS DOCUMENT AND THE REPRODUCTION OF THIS DOCUMENT, IN WHOLE OR IN PART, WITHOUT THE WRITTEN PERMISSION OF SPECTRUM MICROWAVE, INC ARE PROHIBITED.

UNLESS OTHERWISE SPECIFIED		3rd ANGLE PROJECTION	
* INTERPRET DRAWING IAW ASME Y14.100-2004		ANSI	
* DIMENSIONING AND TOLERANCING IAW ASME Y14.5-1994		DRAWN	DATE
* PARENTHEetical INFORMATION FOR REFERENCE ONLY		WAR	2013-03-05
* DIMENSIONAL LIMITS APPLY BEFORE PROCESSES		CHECKED	
* DIMENSIONS ARE IN INCHES		ENGRG	
* TOLERANCES ARE: ANGLES ±1.0°		HP	2013-03-05
63/2 PLACE DECIMAL ±.02		MFG	
3 PLACE DECIMAL ±.005		QA	
* REMOVE ALL BURRS AND SHARP EDGES .010 RAD MAX.			
* SURFACE FINISH			
* CONCENTRICITY MACHINED DIA: .002 FIM			
* MACHINED TOOL MISMATCH: .002 MAX.			
DO NOT SCALE DRAWING			

SPECTRUM MICROWAVE, INC			
2707 Black Lake Place			
Philadelphia, PA 19154-1008 (USA)			
TITLE			
OUTLINE, HF1			
SIZE	CAGE CODE	DWG NO.	REV
B	60979	088-00370	-
SCALE:	SHEET		
2.25:1	1 OF 1		