

NOTES:

- 1. HOUSING & SEAL COVER ALUMINUM, COVER IS LASER WELDED TO FORM A HERMITIC SEAL.
HOUSING: IS NICKEL PLATED PER AMS-C-26074 CLASS 3, GRADE B,
WELD COVER: CHEMICAL FILM MIL-DTL-5541, TYPE II CLASS 3

REVISIONS				
ECN	REV.	DESCRIPTION	CHNG/DATE	APPVD/DATE
XXXXX	P-4-	RELEASE	2016/08/30	

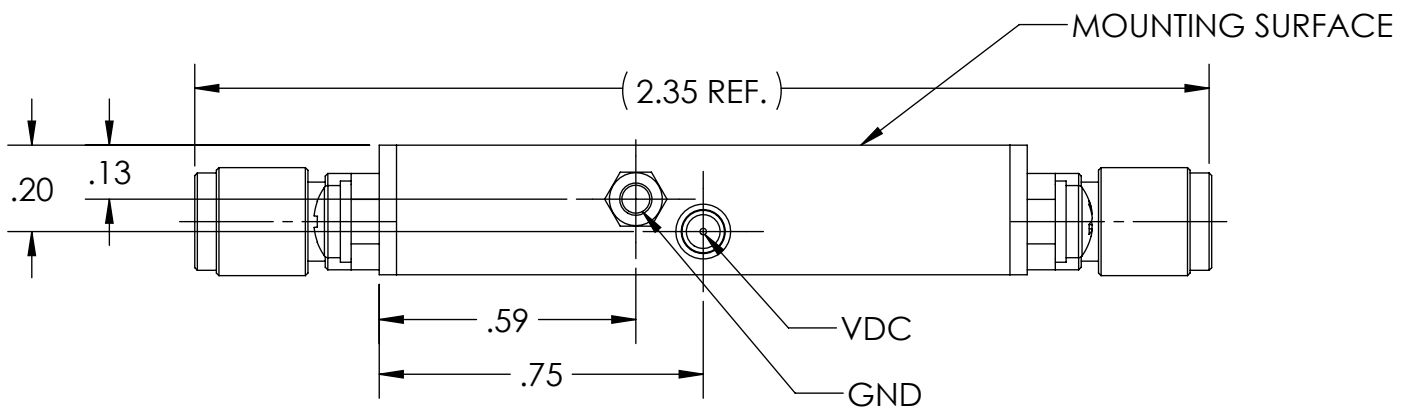
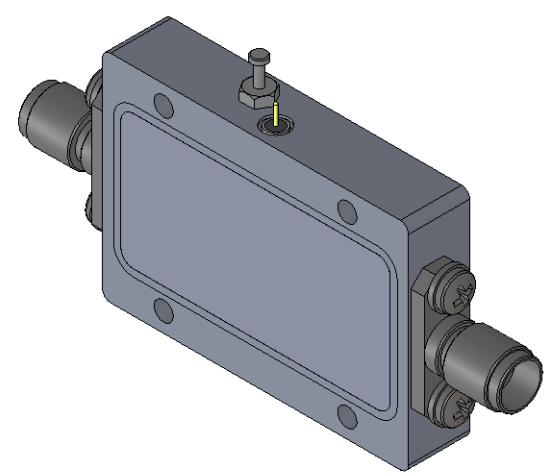

SMA CONNECTORS REMOVED

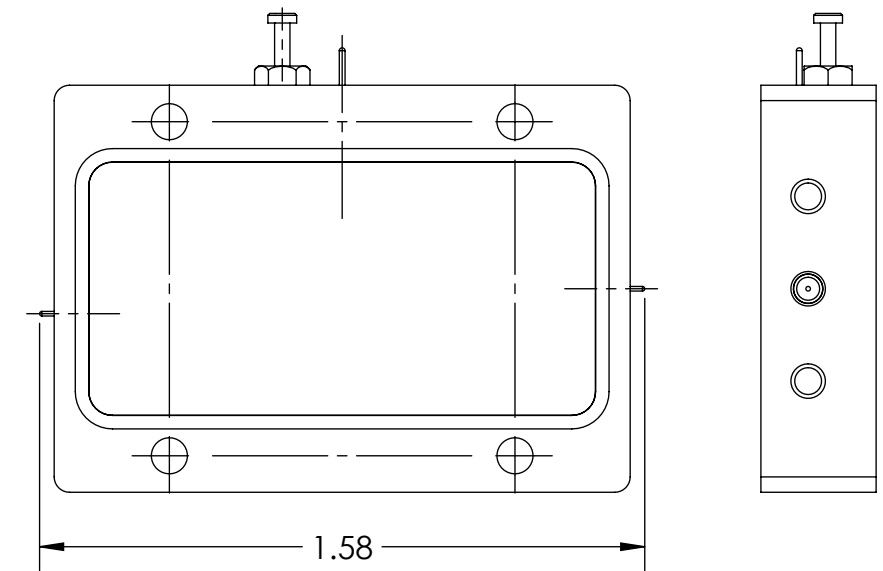
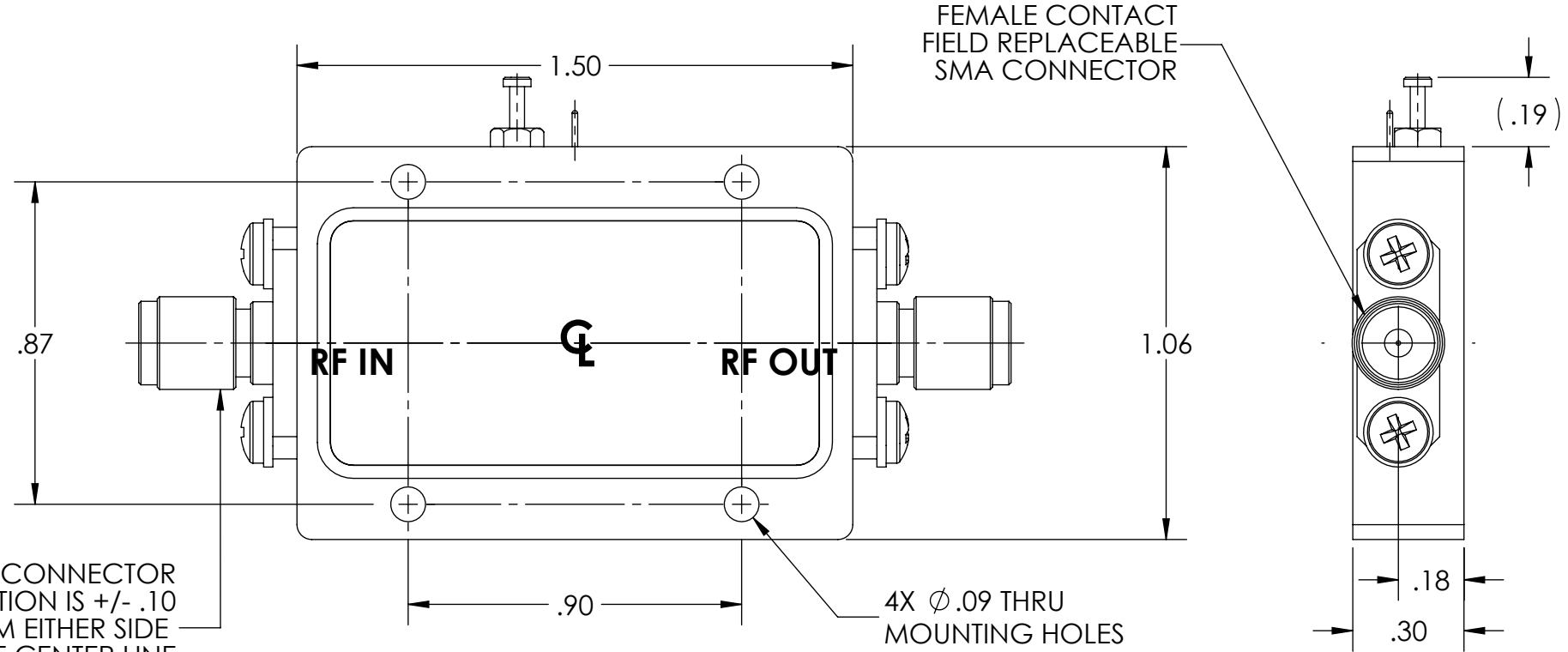

SMA CONNECTOR POSITION IS +/- .10 FROM EITHER SIDE OF THE CENTER LINE TYP BOTH SIDES

SEE SEPARATE PARTS LIST IN ELECTRONIC STORAGE

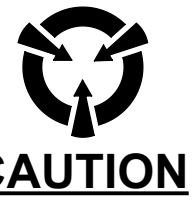

THIS ASSEMBLY CONTAINS PARTS SENSITIVE TO DAMAGE BY ELECTROSTATIC DISCHARGE (ESD). USE ESD PRECAUTIONARY PROCEDURES WHEN TOUCHING, REMOVING OR INSERTING

SPECTRUM MICROWAVE PROPRIETARY INFORMATION
THIS DOCUMENT IS THE SOLE PROPERTY OF SPECTRUM MICROWAVE, INC. THE RELEASE OF DATA CONTAINED IN THIS DOCUMENT AND THE REPRODUCTION OF THIS DOCUMENT, IN WHOLE OR IN PART, WITHOUT THE WRITTEN PERMISSION OF SPECTRUM MICROWAVE, INC ARE PROHIBITED.

UNLESS OTHERWISE SPECIFIED		3rd ANGLE PROJECTION	
<ul style="list-style-type: none"> * INTERPRET DRAWING IAW ASME Y14.100-2004 * DIMENSIONING AND TOLERANCING IAW ASME Y14.5-1994 * PARENTHETICAL INFORMATION FOR REFERENCE ONLY * DIMENSIONAL LIMITS APPLY BEFORE PROCESSES * DIMENSIONS ARE IN INCHES * TOLERANCES ARE: ANGLES ±1.0° * SURFACE FINISH: 63 (2 PLACE DECIMAL ±.02, 3 PLACE DECIMAL ±.005) * REMOVE ALL BURRS AND SHARP EDGES .010 RAD MAX. * CONCENTRICITY MACHINED DIA: .002 FIM * MACHINED TOOL MISMATCH: .002 MAX. 		ANSI	
DRAWN	WAR	DATE	2013-04-04
CHECKED			
ENGRG	HP	DATE	2013-04-04
MFG			
QA			
DO NOT SCALE DRAWING			

SPECTRUM MICROWAVE, INC 2707 Black Lake Place Philadelphia, PA 19154-1008 (USA)			
TITLE OUTLINE, HF2			
SIZE	CAGE CODE	DWG NO.	REV
B	60979	088-00376	-
SCALE:	SHEET		1 OF 1
2.25:1			