

DESCRIPTION

- 868.30 MHz SAW bandpass filter with 1.30 MHz bandwidth.
- 3.8 x 3.8 mm ceramic LCC package, 6 pads.
- RoHS compliant.

TYPICAL PERFORMANCE

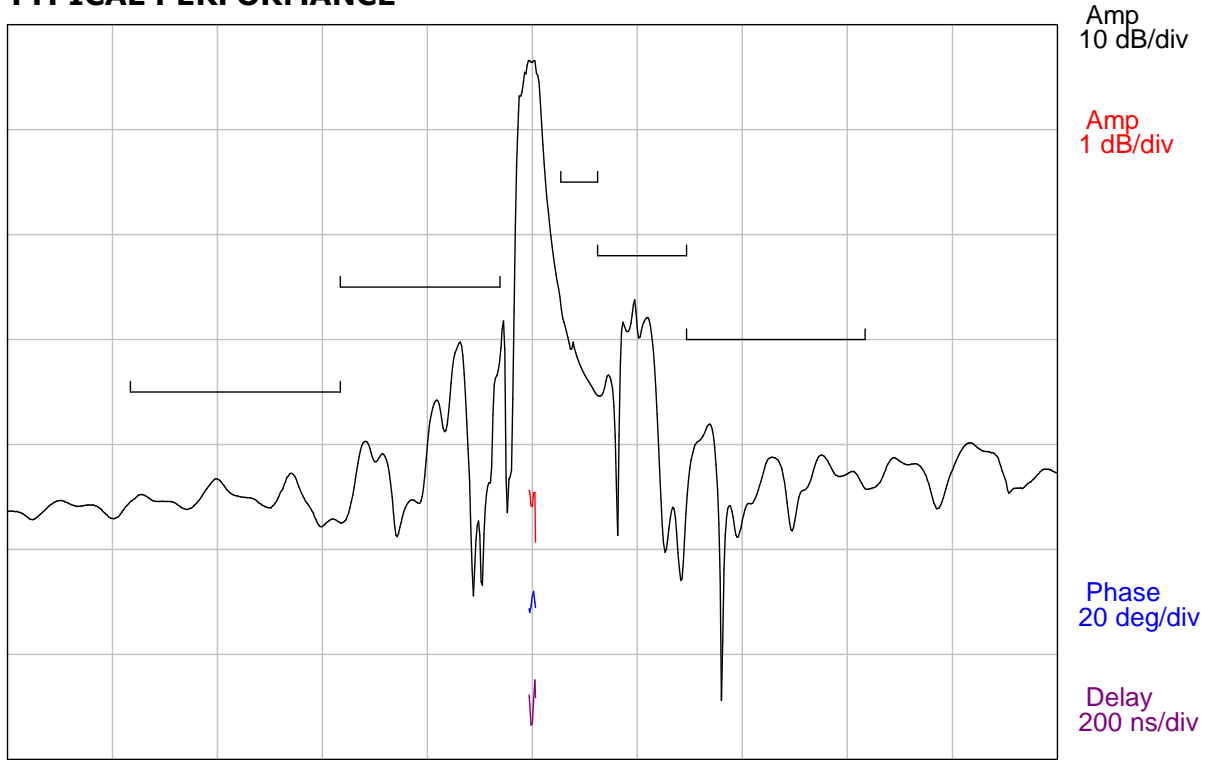

Center = 868.3 MHz, 10 MHz/div (125 kHz incr)

S11 (818.3-918.3 MHz)

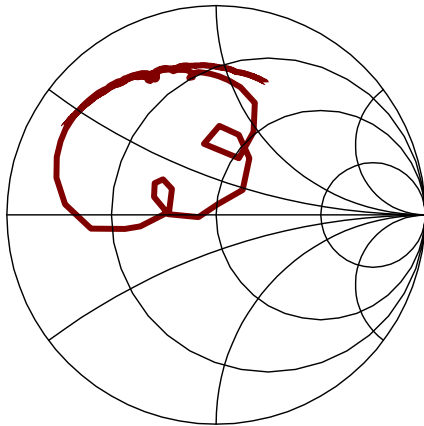

S22 (818.3-918.3 MHz)

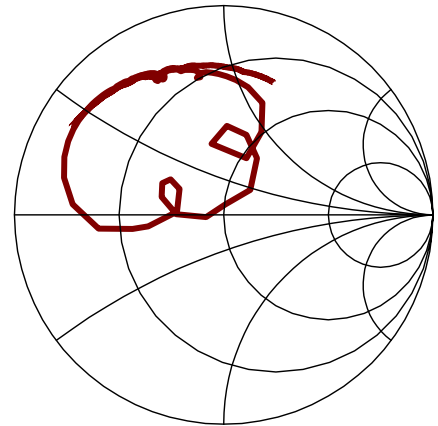

SPECIFICATION

Parameter	Min	Typ	Max	Units
Center Frequency, F_C	-	868.30	-	MHz
Minimum Insertion Loss (IL)	-	3.4	3.8	dB
3 dB Bandwidth	-	1.3	-	MHz
Passband Ripple (868.1 to 868.5 MHz)	-	0.6	2.0	dB p-p
Passband Ripple (868.0 to 868.6 MHz)	-	0.9	3.0	dB p-p
Attenuation (referenced to 0 dB absolute)				
10 to 830 MHz	40	45	-	dB
830 to 850 MHz	35	40	-	dB
850 to 865.2 MHz	25	28	-	dB
865.2 to 867 MHz	4	8	-	dB
869.6 to 871 MHz	3	5.5	-	dB
871 to 874.5 MHz	15	24	-	dB
874.5 to 883 MHz	22	26	-	dB
883 to 900 MHz	30	35	-	dB
900 to 1000 MHz	40	45	-	dB
Impedance at F_C Input $Z_{IN} = R_{IN} // C_{IN}$	210 Ohm // 2.1pF		-	
Output $Z_{OUT} = R_{OUT}$	210 Ohm // 2.1pF		-	
Ambient Temperature	25		°C	

MAXIMUM RATINGS

Parameter	Min	Max	Units
Storage Temperature Range	-45	120	°C
Operating temperature Range	-45	120	°C
Input Power Level	-	+17	dBm
DC Voltage	-	6	V

MATCHING CIRCUIT

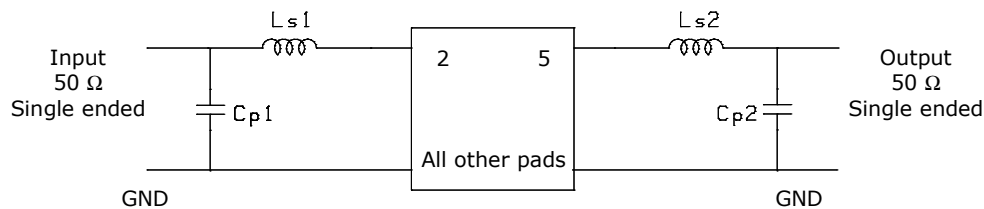

$$Ls1=18 \text{ nH}, Cp1=3 \text{ pF}, Ls2=18 \text{ nH}, Cp2=3 \text{ pF}$$

Notes:

- Recommend $\pm 2\%$ toleranced matching components. Typical inductor $Q=40$.
- Values shown are for reference only. Actual values are dependent upon board layout.

PACKAGE OUTLINE

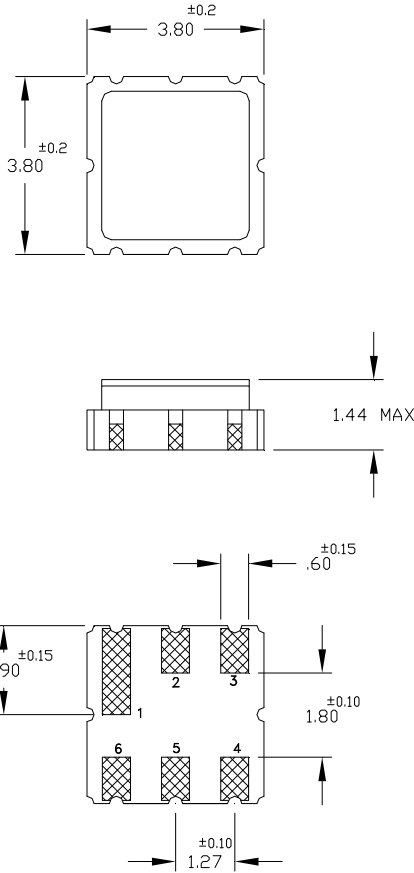

Units: mm

Tolerances are typically ± 0.15 mm except where indicated.

Pad Configuration:

Input: 2
 Output: 5
 Ground: All other pads

Package Material:

Body: Al_2O_3 ceramic
 Lid: Kovar, Ni plated
 Terminations: Au plating $1 \mu\text{m}$ min, over a $1.3\text{-}8.9 \mu\text{m}$ Ni plating

MARKING

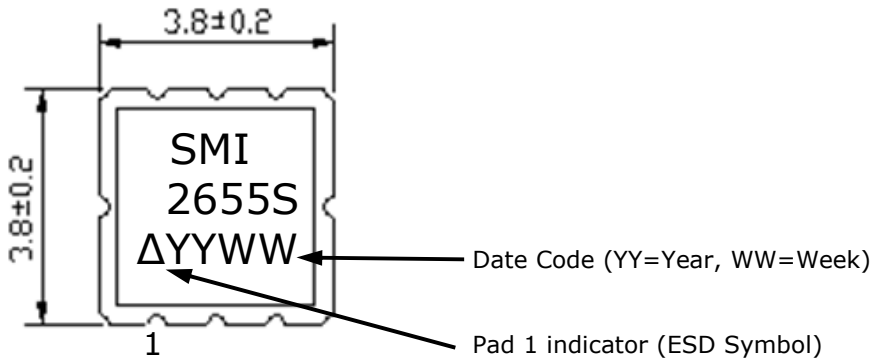

**ISO 9001
 Registered**

All specifications are believed to be accurate and reliable. However, Spectrum Microwave reserves the right to make changes without notice.
 © 2010 All rights reserved.